

avintage●●●

2-compartment service wine cabinet

17 bottles*

AV18CDZ

-
- *Free standing and built-in under counter installation*
 - *Cooling system: compressor (ventilated cooling)*
 - *Adjustable temperature range of use: 5°-22°C*
 - *Black metal external body*
 - *Black PVC inner liner*
 - *1 reversible glass door, anti-UV treated, 3-layers tempered glass (grey-colored), black piano organic glass frame*
 - *Electronic regulation*
 - *4 sliding wooden shelves*





Reference: AV18CDZ

- **Ambient temperature range of use:**
5°-32°C
- **Equipments included:**
4 adjustable feet (height 7 cm)
White LED lights with ON/OFF switch button
Anti-vibration system
Removable aeration system
Winter system
Thermometer with electronic display (blue)
- **Technical characteristics:**
Voltage: 220-240 V
Power input: 85.0 W
Annual electrical consumption: 138.0 kWh
Energy class: A
Climatic class: ST
Noise level: 42.0 dB

• Logistic datas:

Dimension UVC (W x D x H cm):

Packed: 32.6x62.8x86.5

Unpacked: 29.5x57x82

Weight UVC (Kg):

Gross: 28,00

Net: 26,00

Pallet dimensions (cm): 0

Full truck (UVC): 0

Container (UVC):

20': 142

40': 304

40' HC: 383

Gencod UVC:

3595320103960

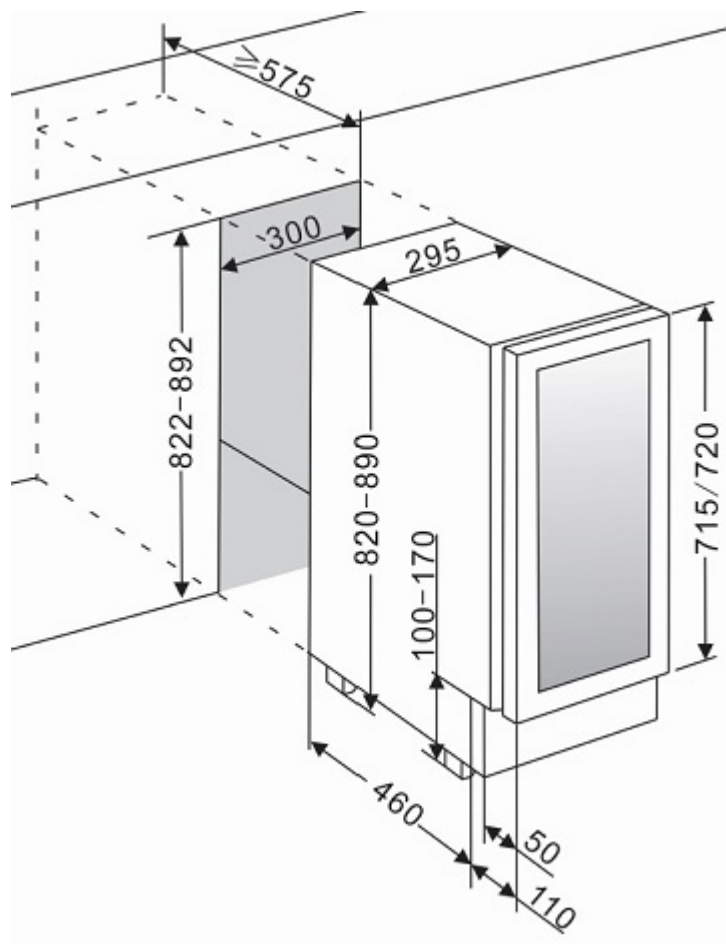

Non-contractual pictures

* Capacity given with 75cl Bordeaux traditional type bottles. Adding shelves reduce considerably the total capacity.