

avintage

Built-under range

2-compartments service wine cabinet

17 bottles*

AVU18CDZA

- Free standing and built-under counter installation
- Cooling system: compressor (air moving system)
- Adjustable temperature range of use:
10°-20°C/5°-10°C
- Black metal external body
- Black PVC inner liner
- 1 reversible glass door, anti-UV treated, 2-layers tempered glass (brown colored), black piano organic glass frame
- Electronic regulation
- 3 semi-sliding metal shelves, wooden front

An Avintage innovation!
New elegant design and optimization of energy consumption: **A class.**

Thanks to **door and temperature alarms**, offer the best protection to your bottles of wine.



avintage

Reference: AVU18CDZA

- **Ambient temperature range of use:**
0°-38°C
- **Equipments included:**
4 adjustable feet (height 6.5 cm)
White LED lights with ON/OFF switch button
Anti-vibration system
Removable aeration system
Winter system
Water tray to maintain proper hygrometry
Thermometer with electronic display (white)
- **Technical characteristics:**
Voltage: 220-240 V
Power input: 74 W
Annual electrical consumption: 138 kWh
Energy class: A
Climatic class: N-ST
Noise level: 43 dB
- **Logistic datas:**

Dimension UVC (W x D x H cm):

Packed: 34x63x85
Unpacked: 29.5x57.3x82

Weight UVC (Kg):

Gross: 34,00
Net: 32,00

Pallet dimensions (cm): 0

Full truck (UVC): 252

Container (UVC):

20': 146
40': 294
40' HC: 366

Gencod UVC: 3595320105285

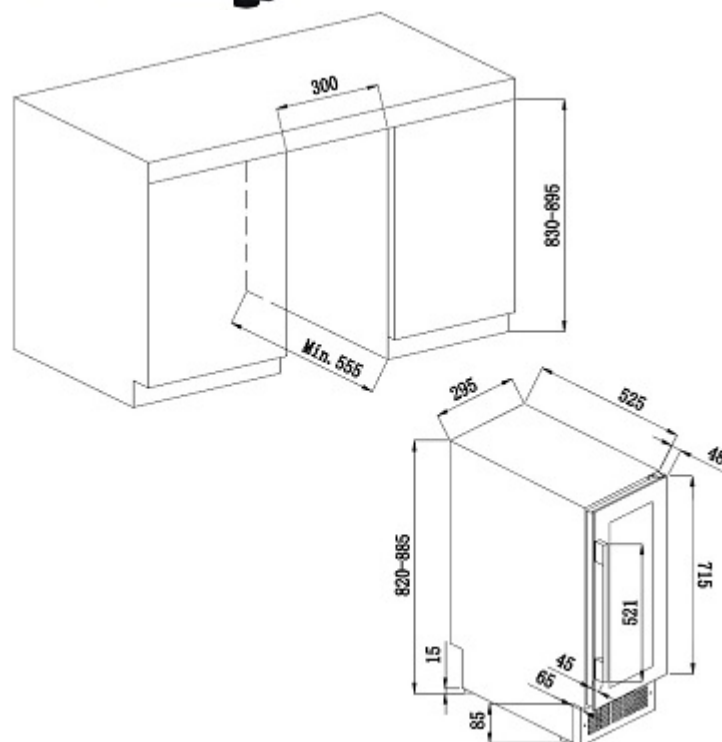

Non-contractual pictures

* Capacity given with 75cl Bordeaux traditional type bottles. Adding shelves reduce considerably the total capacity.